

IGNITION

START

22 AWG WIRE

20 Amp Relay
With 12 Volt Coil

14 AWG WIRE

14 AWG WIRE

TO STARTER
MOTOR

22 AWG WIRE

30 Amp
Fuse

8 AWG WIRE

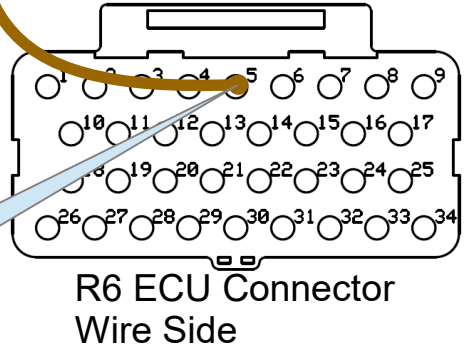

Fan Control

R6 ECU Connector
Wire Side



ALL GROUNDED
TOGETHER ON
MAIN ENGINE
CASES

8 AWG WIRE

8 AWG WIRE

+ BATTERY -

MAIN ENGINE HARNESS